



MLS 7084807 Residential

\$119,900

952 sq ft
2 bedrooms
2 baths

513 5th Ave
Ironton MN 56455

Status: Active

Description:

Welcome to 513 5th Avenue, Ironton

If you've been looking for a place that feels like a true Minnesota small-town home — quiet streets, friendly neighbors, and the great outdoors right out your back door — this is it.

This 2-bedroom, 1-bath home sits on a large double lot in the heart of Ironton, just a few blocks from everything that makes this community special. Inside, you'll find an easy-flowing layout that feels welcoming the moment you walk in.

Outside, you'll enjoy the huge 3 car garage. Great for project or just extra storage

But the real magic of this home is where it sits.

You're only minutes from the world-famous Cuyuna Country State Recreation Area — known across the country for its mountain biking trails, scenic mine-pit lakes, and year-round outdoor activities. Bike, hike, swim, fish, kayak, snowshoe — it's all right here. Downtown Crosby and Ironton offer great local restaurants, coffee shops, and small-town events that bring the community together.

Whether you're looking for a primary home, a weekend getaway, or a smart investment in one of Minnesota's most exciting recreation areas, 513 5th Avenue gives you a comfortable place to land in a town that's quietly becoming one of the best-kept secrets in the state.

Come take a look. You'll see what we mean.

Additional Details:

Year Built	1980
Lot Acres	0.11
Lot Dimensions	75x120
Garage Stalls	3
School District	182
Taxes	\$976
Taxes with Assessments	\$976
Tax Year	2025

Additional Features:

Basement: None **Fuel:** Natural Gas **Garage:** 3 **Heat:** Forced Air **Sewer:** City Sewer/Connected **Water:** City Water/Connected **Air Conditioning:**

 Listed By:
 Realty Inc

Call Affinity Real Estate, Inc Broker Reciprocity (sm) program, allowing us to display other broker's listings on our website. All properties are subject to prior sale, change or withdrawal.



Call Affinity Real Estate

218-237-3333

info@affinityrealestate.com



Affinity Real Estate - 600 Park Avenue South - Park Rapids MN 56470



website: www.AffinityRealEstate.com | email: info@affinityrealestate.com | office: 218-237-3333 | fax:218-237-3377



\$119,900
MLS 7084807 Residential
513 5th Ave
Ironton MN 56455

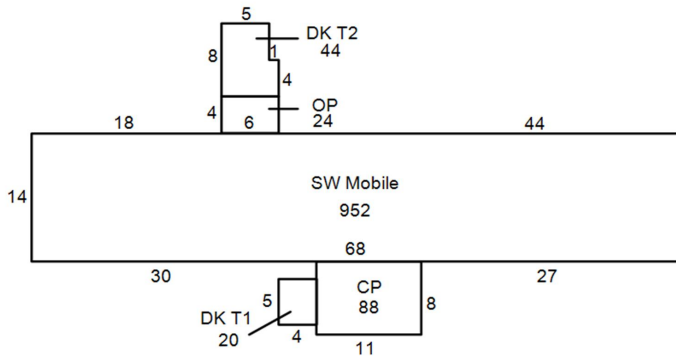

website: www.AffinityRealEstate.com | email: info@affinityrealestate.com | office: 218-237-3333 | fax: 218-237-3377



\$119,900
 MLS 7084807 Residential
 513 5th Ave
 Ironton MN 56455

website: www.AffinityRealEstate.com | email: info@affinityrealestate.com | office: 218-237-3333 | fax:218-237-3377



\$119,900
MLS 7084807 Residential
513 5th Ave
Ironton MN 56455